

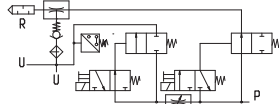

# SINGLE-STAGE AND MULTI-FUNCTION VACUUM GENERATORS, MSVE SERIES

3D drawings available at [vuototecnica.net](http://vuototecnica.net)

The vacuum generators of this new series can fully drive a negative pressure gripping system. By means of coaxial shutters, the original compressed air supply system feeds large quantities of air to both the ejectors and the ejection system, thereby ensuring faster gripping and release of the load. These vacuum generators are equipped with single-stage ejectors, are powered by low pressure (max. 4 bar), and feature an extremely high emptying speed in relation to their suction capacity. All this allows for increasingly faster high-performance work cycles. Two micro solenoid valves manage the compressed air supply to the vacuum ejector and adjustable discharge blow off. The intensity and duration of the latter are managed through a screw-type flow regulator. The check valve built into the suction connector maintains the vacuum in the event of a power outage. A digital vacuum switch, equipped with a display and commutation LED, manages the compressed air supply and provides a signal to start a cycle under safety conditions. An anodised aluminium distributor with vacuum connectors has an integrated suction filter that can be easily inspected. By activating the compressed air power micro solenoid valve, the generator creates vacuum for use. As soon as the set maximum value is reached, the digital vacuum switch acts on the electric coil of the micro solenoid valve and stops the air supply, reactivating it when the vacuum falls below the minimum level. Besides maintaining the vacuum level within set safety values (hysteresis), this modulation allows for considerable compressed air savings. A second signal from the vacuum switch (also adjustable and independent with respect to the first) can be used to start the cycle when the vacuum level reached is suitable for use. Once the work cycle is completed, the micro solenoid valve that supplies compressed air to the generator is deactivated while, at the same time, the ejection solenoid valve is activated for quick restoration of the atmospheric pressure upon use. The MSVE vacuum generators can be installed in any position and are suitable for suction gripping systems, handling metal sheets, glass, marble, ceramics, plastic, cardboard, wood, etc. and, in particular, for the industrial robotics sector, where equipment with excellent performance and limited weight and bulk are increasingly required.

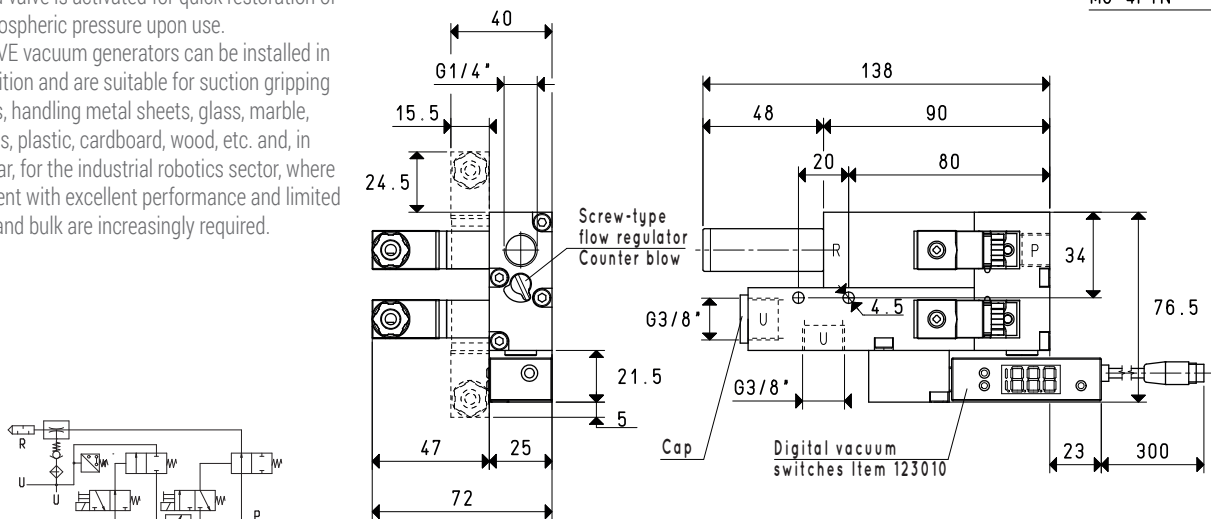
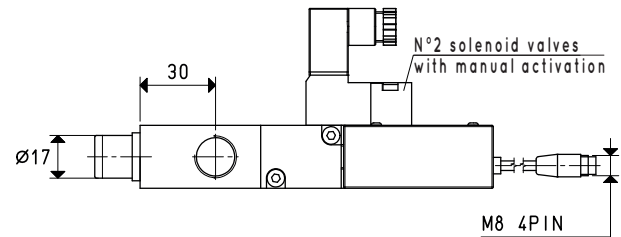
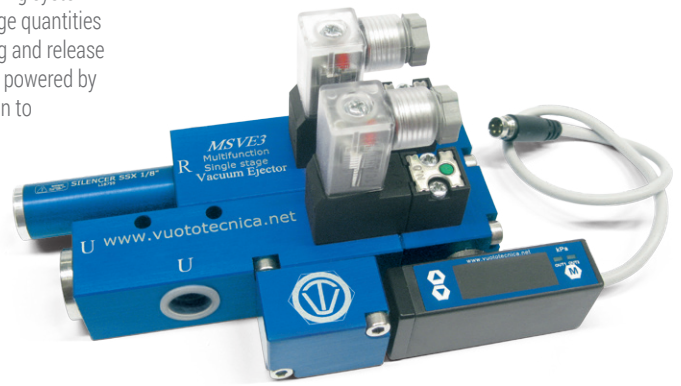

P=COMPRESSED AIR CONNECTION      R=EXHAUST      U=VACUUM CONNECTION

Item		MSVE 3						MSVE 5
Quantity of sucked air	cum/h	2.6	2.7	2.7	4.5	4.9	4.9	
Max. vacuum level	-kPa	40	64	85	40	64	85	
Final pressure	mbar ass.	600	360	150	600	360	150	
Supply pressure	bar	2	3	4	2	3	4	
Air consumption	NI/s	0.7	0.9	1.2	1.3	1.7	2.2	
Max. quantity of blown air at 3.5 bar (g)	l/min			620			620	
Internal supply coaxial shutter position				NO			NO	
Supply solenoid valve absorption	W			2.0			2.0	
Internal ejection coaxial shutter position				NC			NC	
Ejection solenoid valve absorption	W			2.0			2.0	
Supply voltage	V			24DC			24DC	
Vacuum switch output				PNP			PNP	
Class of protection	IP			40			40	
Working temperature	°C			-10 / +60			-10 / +60	
Noise level at optimal supply pressure	dB(A)			68			74	
Weight	g			493			493	

Note: To order a generator with NC supply coaxial shutter, please indicate item code MSVE..NC.

To order a generator without the digital vacuum switch, please indicate the item code MSVE..SV.

Note: All the vacuum data indicated in the table are valid at the normal atmospheric pressure of 1013 mbar and are obtained with a constant supply pressure.

Conversion ratio: N (newton) = Kg x 9.81 (G-force) ; inch =  $\frac{\text{mm}}{25.4}$  ; pounds =  $\frac{\text{g}}{453.6} = \frac{\text{Kg}}{0.4536}$

GAS-NPT thread adapters available at page 1.128

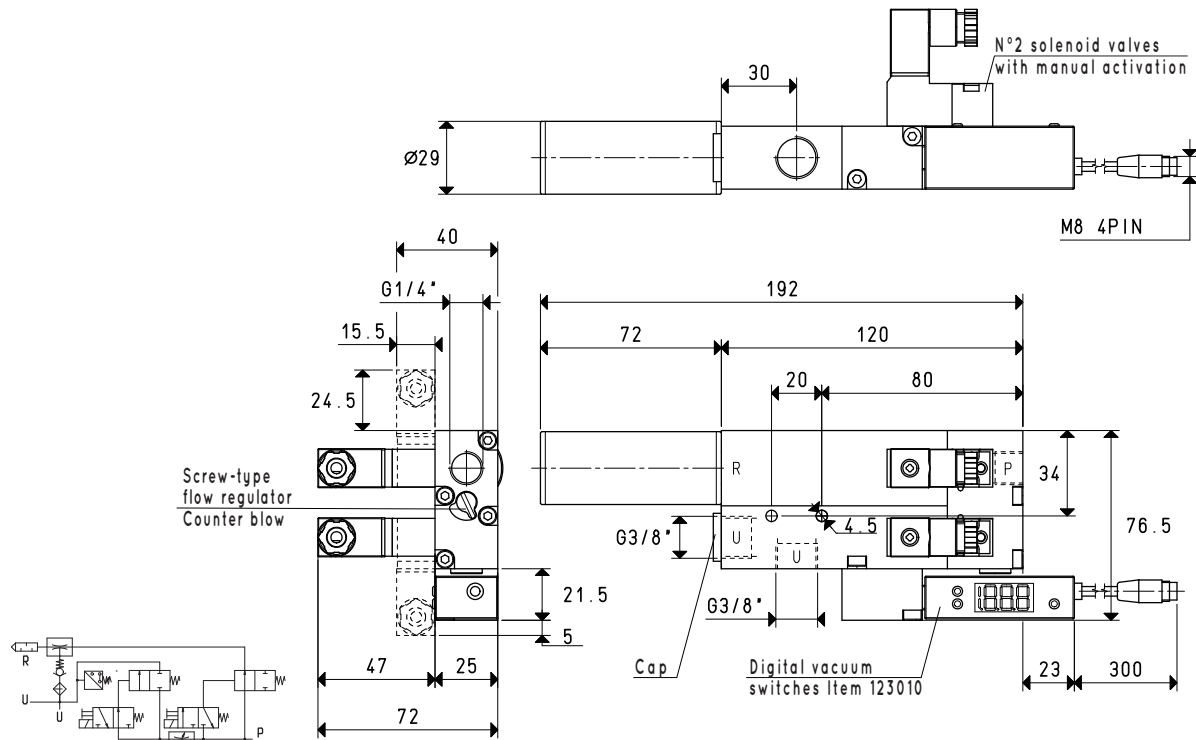
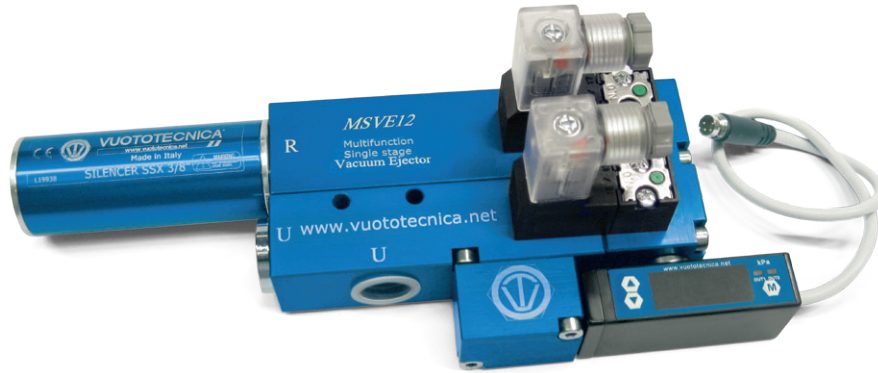

P=COMPRESSED AIR CONNECTION      R=EXHAUST      U=VACUUM CONNECTION

Item		MSVE 8					MSVE 12
Quantity of sucked air	cum/h	8.0	8.6	8.8	12.0	12.2	12.5
Max. vacuum level	-kPa	40	60	90	40	60	90
Final pressure	mbar ass.	600	400	100	600	400	100
Supply pressure	bar	2	3	3.5	2	3	3.5
Air consumption	Nl/s	2.8	3.8	4.3	3.7	5.0	5.5
Max. quantity of blown air at 3.5 bar (g)	l/min			600		600	
Internal supply coaxial shutter position				NO		NO	
Supply solenoid valve absorption	W			2.0		2.0	
Internal ejection coaxial shutter position				NC		NC	
Ejection solenoid valve absorption	W			2.0		2.0	
Supply voltage	V			24DC		24DC	
Vacuum switch output				PNP		PNP	
Class of protection	IP			40		40	
Working temperature	°C			-10 / +60		-10 / +60	
Noise level at optimal supply pressure	dB(A)			53		50	
Weight	g			580		620	

Note: To order a generator with NC supply coaxial shutter, please indicate item code MSVE..NC.

To order a generator without the digital vacuum switch, please indicate the item code MSVE..SV.

Note: All the vacuum data indicated in the table are valid at the normal atmospheric pressure of 1013 mbar and are obtained with a constant supply pressure.

Conversion ratio: N (newton) = Kg x 9.81 (G-force) ; inch =  $\frac{mm}{25.4}$  ; pounds =  $\frac{g}{453.6} = \frac{Kg}{0.4536}$

GAS-NPT thread adapters available at page 1.128