

To calculate the emptying time of a volume of V_1 , use the following formula: $t_1 = \frac{t \times V_1}{100}$

- Curve relative to the flow rate (referring to the suction pressure)
- - - Curve relative to the flow rate (referring to a 1013 mbar pressure)
- Curve regarding the emptying time of a 100-litre volume

- V_1 : Volume to be emptied (l)
- t_1 : time to be calculated (sec)
- t : time obtained in the table (sec)

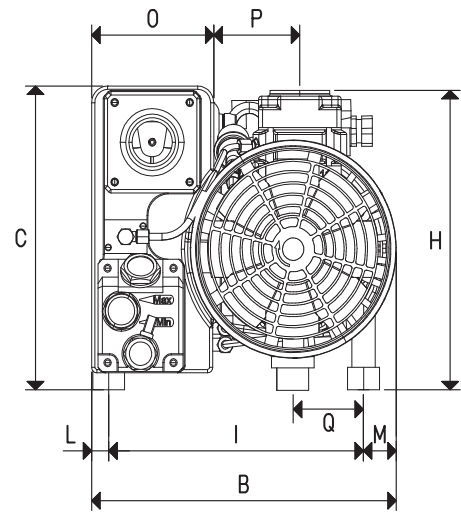
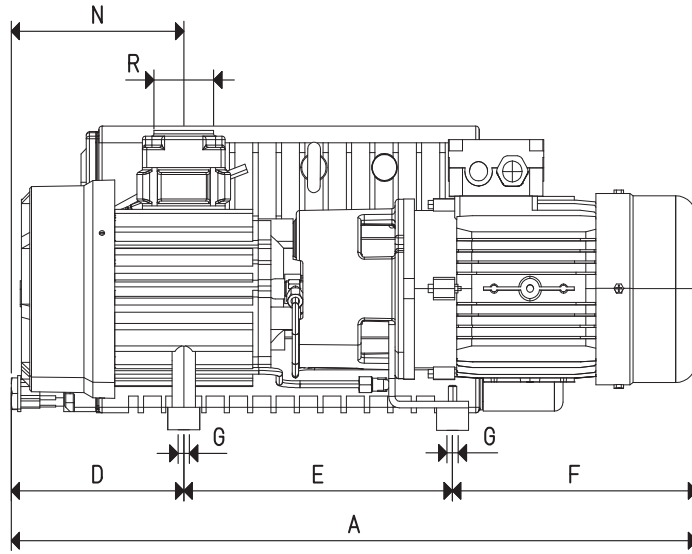

Item		RVP 40	
Frequency		50 Hz	60 Hz
Flow rate	m ³ /h	40.0	48.0
Final pressure	mbar abs.	0.5	
H₂O steam quantity permitted	Kg/h	0,7	
Motor performance 3~	Volt	230/400 ± 10%	275/480 ± 10%
Motor power 3~	Kw	1.10	1.35
Motor protection	IP	55	
Rotation speed	g/min ⁻¹	1450	1740
Motor shape		B14	(flange hole spacing 130 mm)
Motor size		100	
Noise level	dB(A)	64	65
Max weight	Kg	49.0	
A		645	
B		286	
C		266	
D		157	
E		323	
F		225	
G	∅	M8	
H		260	
I		240	
L		15	
M		31	
N		157	
O		115	
P		80	
Q		66	
R	∅ gas	G1"1/4	
Accessories and Parts		RVP 40	
Oil charge	L	1.25	
Lubricating oil	type	VT OIL 100	
Oil filter	item	00 RVP 40 07	
Deoiling cartridge	item	00 RVP 40 05	
3 vanes	item	00 RVP 40 04	
Sealing kit	item	00 RVP 40 06	
Check valve	item	00 RVP 40 03	
Suction filter	item	FC 35	
Ballast valve	item	integrated	