

To calculate the emptying time of a volume of V_1 , use the following formula: $t_1 = \frac{t \times V_1}{100}$

- Curve relative to the flow rate (referring to the suction pressure)
- - - Curve relative to the flow rate (referring to a 1013 mbar pressure)
- Curve regarding the emptying time of a 100-litre volume

V_1 : Volume to be emptied (l)
 t_1 : time to be calculated (sec)
 t : time obtained in the table (sec)

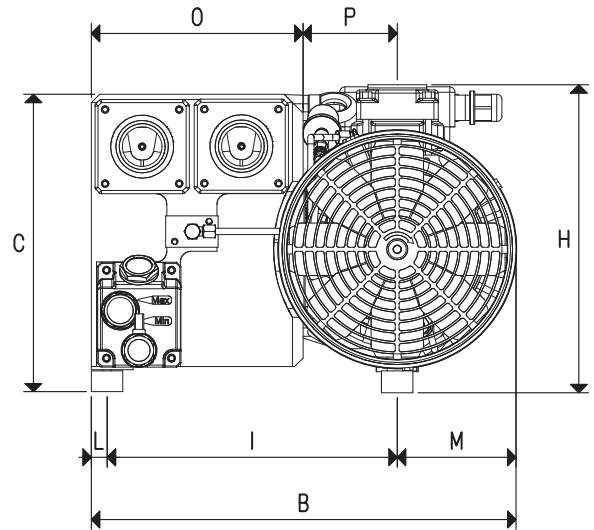
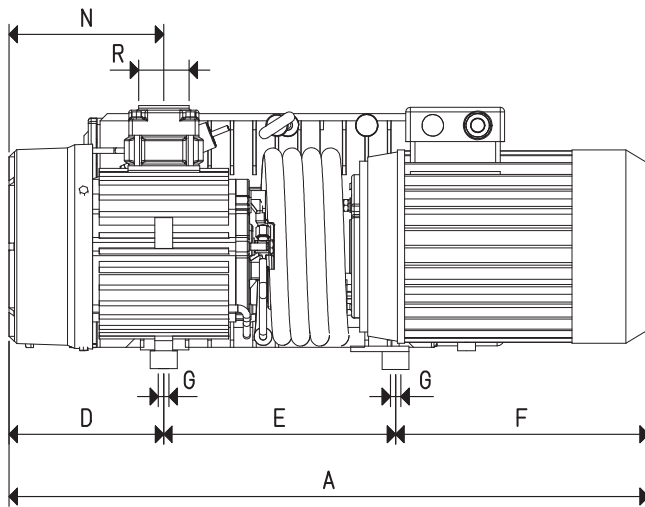

Item		RVP 100	
Frequency		50 Hz	60 Hz
Flow rate	m ³ /h	100.0	120.0
Final pressure	mbar abs.	0.5	
H ₂ O steam quantity permitted	Kg/h	1.5	
Motor performance 3~	Volt	230/400 ± 10%	275/480 ± 10%
Motor power 3~	Kw	2.2	3.0
Motor protection	IP	55	
Rotation speed	g/min ⁻¹	1450	1740
Motor shape		B14	(flange hole spacing 130 mm)
Motor size		100	
Noise level	dB(A)	67	69
Max weight	Kg	78.0	
A		710	
B		405	
C		280	
D		175	
E		360	
F		275	
G	∅	M8	
H		290	
I		277	
L		15	
M		113	
N		170	
O		200	
P		90	
R	∅ gas	G1"1/4	
Accessories and Parts		RVP 100	
Oil charge	L	2	
Lubricating oil	type	VT OIL 100	
Oil filter	item	00 RVP 100 07	
2 deoiling cartridges	item	00 RVP 100 05	
3 vanes	item	00 RVP 100 04	
Sealing kit	item	00 RVP 100 06	
Check valve	item	00 RVP 100 03	
Suction filter	item	FC 35	
Ballast valve	item	integrated	